

## RAIL INSTALLATION USER OPERATING INSTRUCTIONS

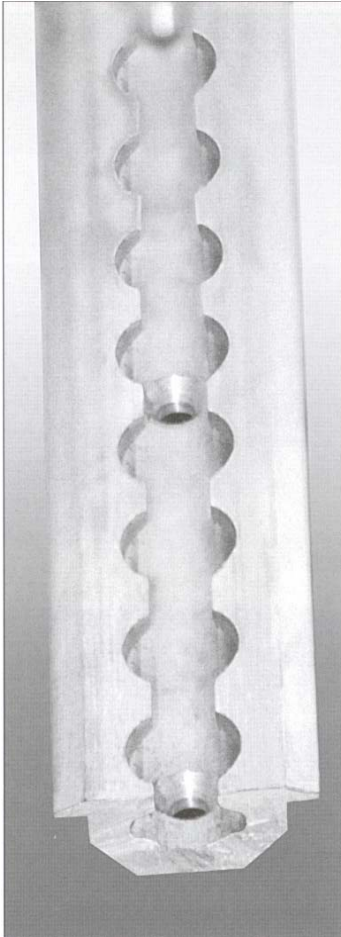

**LOW PROFILE**

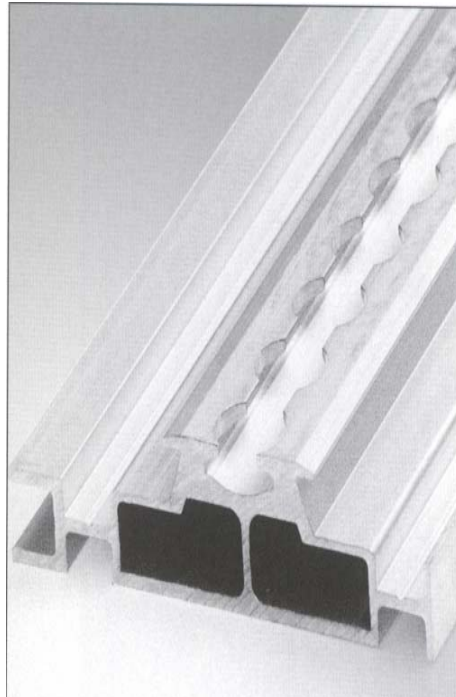

**HEAVY DUTY**

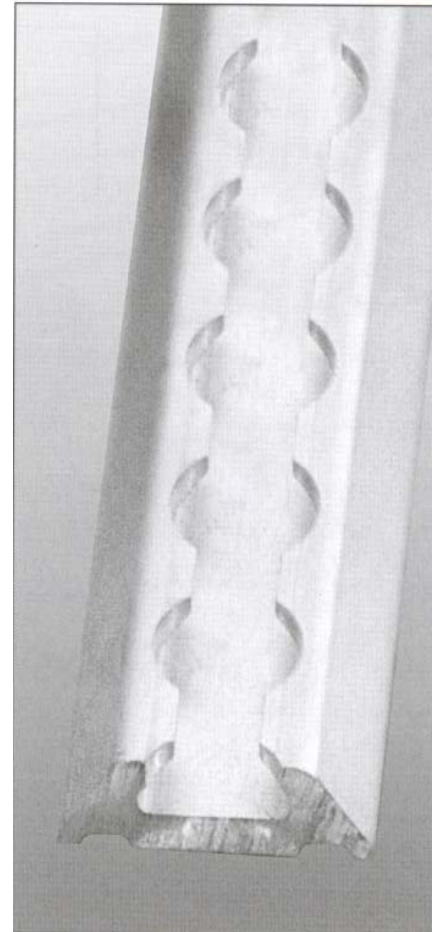

**SURFACE RAIL**

**Read instructions fully before use.  
Retain this manual for future reference.  
Include it with the product in the event of transfer to new users.  
Additional copies are available upon request.**

Unwin House • The Horseshoe • Coat Road  
Martock • Somerset • TA12 6EY • ENGLAND  
Tel: +44 (0)1935 827740 • Fax: +44 (0)1935 827760  
Email: [sales@unwin-safety.co.uk](mailto:sales@unwin-safety.co.uk)  
[www.unwin-safety.com](http://www.unwin-safety.com)

© 2008 C.N. UNWIN LTD. ALL RIGHTS RESERVED

UI1394A

## CONTENTS

- A. Types of rail available
- B. Limitations of use
- C. Installation
- D. Maintenance

## A. TYPES OF RAIL AVAILABLE

Unwin Low Profile Rail  
Unwin Heavy Duty Rail  
Unwin Surface Rail

## B. LIMITATIONS OF USE

1. Unwin Low Profile and Surface floor rails correctly fitted and secured with M8 fasteners, are capable of meeting the strength requirements of M1 load.
2. Unwin Heavy Duty rail, correctly installed, is capable of meeting the strength requirements of M1 load.
3. Unwin Surface rail is also designed for fitting to a vehicle side wall as a “cant rail” for third point occupant restraint fitment or can be use as location for equipment stowage.
4. Unwin products are extensively tested using Unwin rail, and our full warranty normally only applies to Unwin equipment when used in Unwin branded rail. Unwins have also participated in test programs with manufacturers of structural rail products and will support warranty on the Unwin products when used in conjunction with such jointly tested systems.  
For further details on specific applications please contact the Sales Office.  
In other situations using rail products for which Unwin has not participated in joint test programs, a limited Unwin warranty will apply.

## C. INSTALLATION

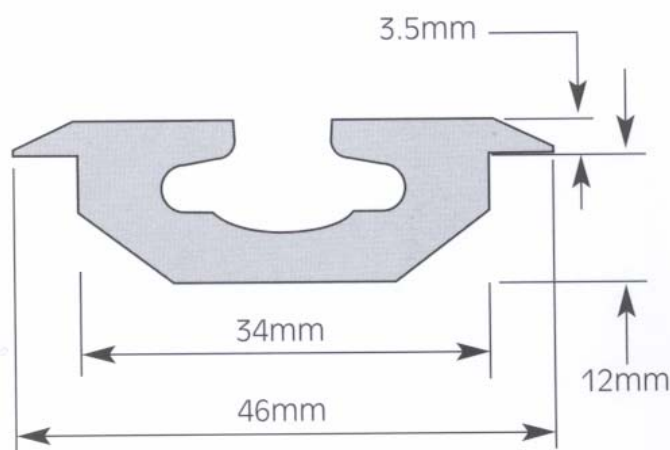

CROSS-SECTION OF LOW PROFILE RAIL

## LOW PROFILE RAIL

1. Standard low profile rail is produced in a 3.66 metre lengths.
2. There are 145 x 20 mm “scallop” in the top face and the base has 37 x m8 countersunk holes at 101.6 mm pitch for the fasteners.
3. As an option the rail can be supplied without the base holes machined.

In this case the machinist must ensure the hole pitches are as recommended, and the countersink depths are critically controlled to avoid weakening the rail.

### Note 1

1. The minimum acceptable length of rail that can safely be installed in a vehicle is 1300 mm. This will accommodate one wheelchair positioned centrally.
2. The rail must be fitted ensuring fasteners are fitted to the extreme end hole positions.

### Note 2

1. For details of the space required within a vehicle for a wheelchair installation, reference should be made to the guidelines within the British or International standard ISO 10542-1 part 2, “Technical systems and aids for disabled or handicapped persons - Wheelchair Tiedown and Occupant Restraint Systems”.

### Note 3

1. Some vehicle layouts may have problems using Low Profile rail with pre-drilled countersunk holes due to under floor obstructions, such as box sections or angle brackets. In these situations where a hole is “missed”, it is required to generate two new holes, one on either side of the original, with the maximum distance between them being 101 mm.
2. The original unused hole must finally be filled with a short self-tapping screw with a matching head.

### Note 4

1. It is critical that the installed rail is flat along its length and correctly positioned relative to any other rail lengths fitted in the vehicle floor. Elements within a pattern of rails must also be parallel to one another. This is particularly important if fitting Unwin “Fixed Base Equipment” or manufacturing removable seats, to ensure they will fit universally along the rails.
2. Unwin recommend that installers use a rail jig (rail accessory D) to ensure that paired rails are parallel with each other within acceptable tolerances. Unwin seat fixtures, when correctly fitted to the seat legs, will accept a rail fitting tolerance of +/- 1mm on nominal set leg centres. Rail centre to centre variations outside this tolerance band may lead to seats jamming or to seats not being able to be fitted easily in the rail at difference positions.

### Fasteners for Low Profile rail

The standard fixing kit for each rail hole consists of:

- An M8 plated screw grade 10.9, socket hex countersunk head, length 45 mm.
- An M8 nylok nut, steel grade 10, plated.
- An M8 30 mm diameter plated steel washer.

All fasteners must be torque loaded to 11 Newton metres (8 foot pounds).



### Under-floor Spreader

Under-floor spreader plates are used with rail fasteners in place of washers to enable rail to be fitted to angled floor sections or where it would be difficult to position a washer.

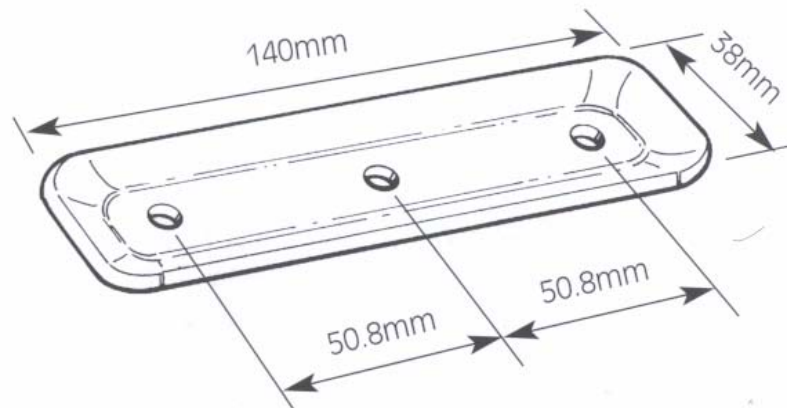

### Rail accessories

A = Metal End Cap

B = Rail Insert (strip)

C = Rail Insert (305 mm)

D = Rail Jig, to aid fitting parallel rails @ 330 mm pitch

A

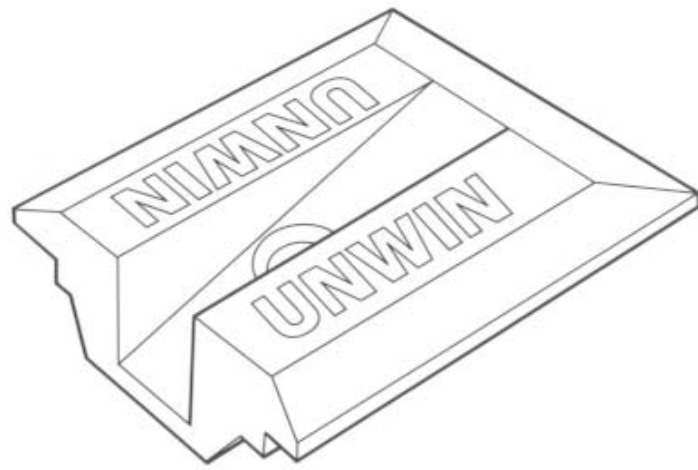

B

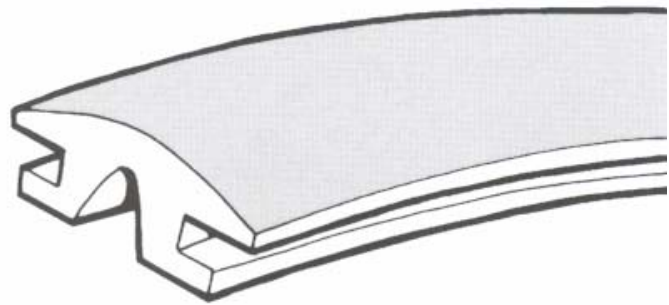

C

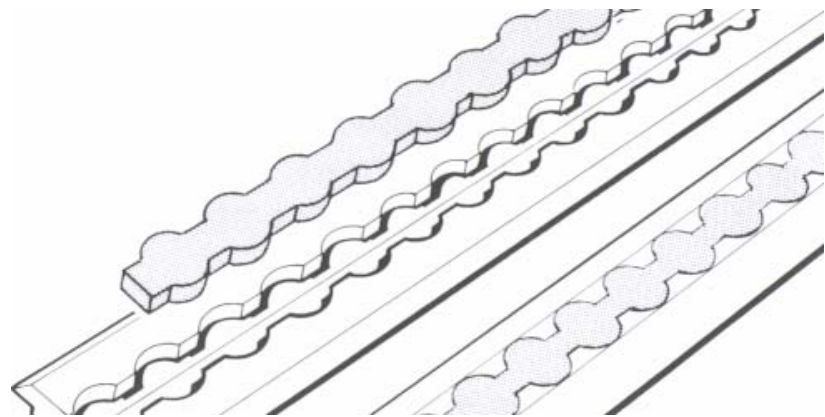

D

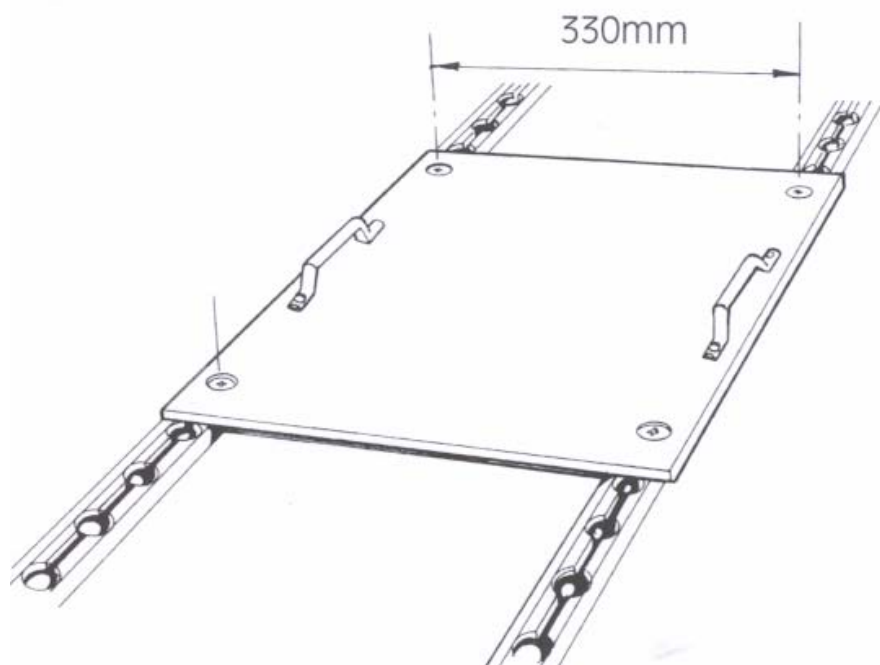

## HEAVY DUTY RAIL

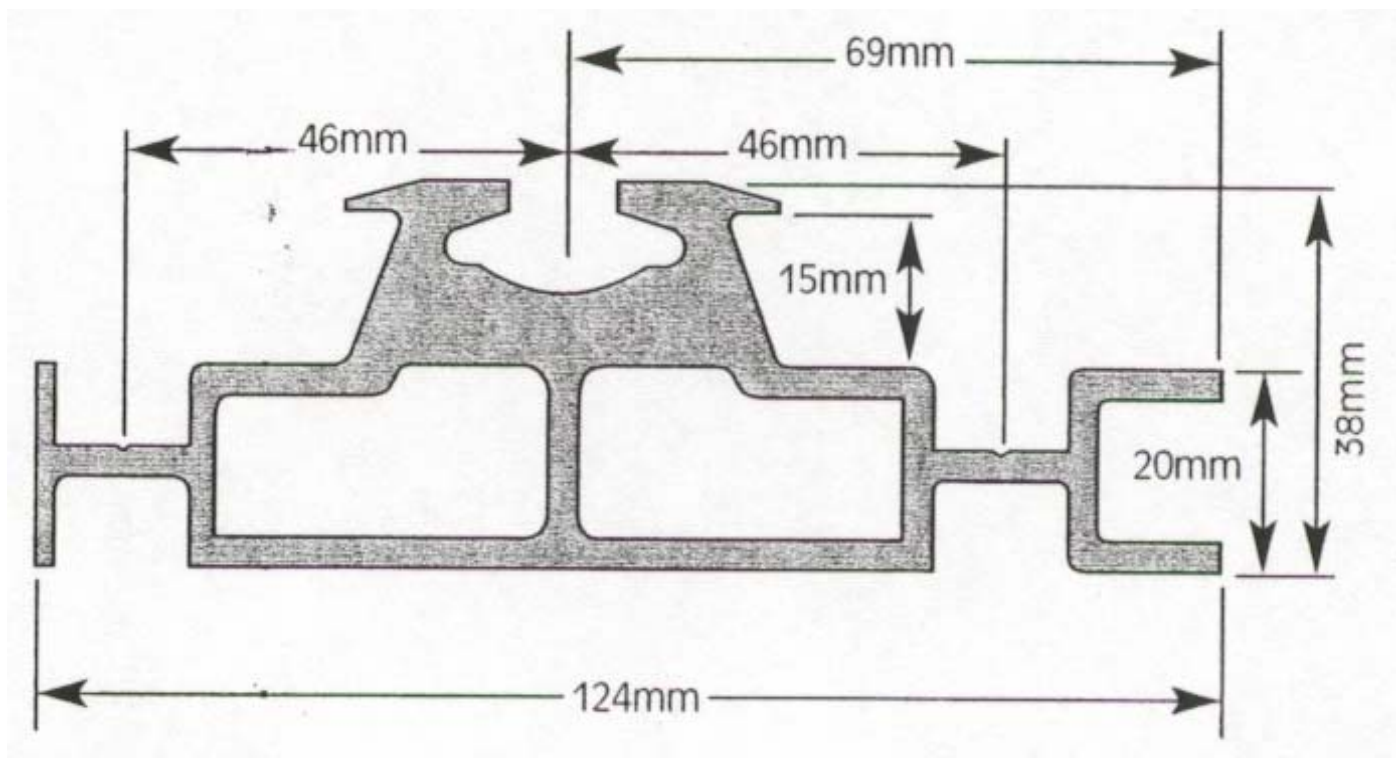

Available in 3.95 and 4.50 metre lengths, this rail profile can be installed with a maximum unsupported span of 600 mm under normal conditions.

Additional fasteners must be fitted at the ends of the rail, in particular at the rear end.

### Fasteners to be used on installation

Bolts:- M8 steel, hexagon headed grade 8.8, plated, guide length 40 - 50 mm.

Nuts:- M8 steel, nylok, grade 8, plated.

Washers:- M8 steel, plain, plated.

Torque settings:- 20 nm (15 lbs/ft).

### Under Floor Reinforcement

Contact Unwin Safety Systems for specific recommendations.

## SURFACE RAIL

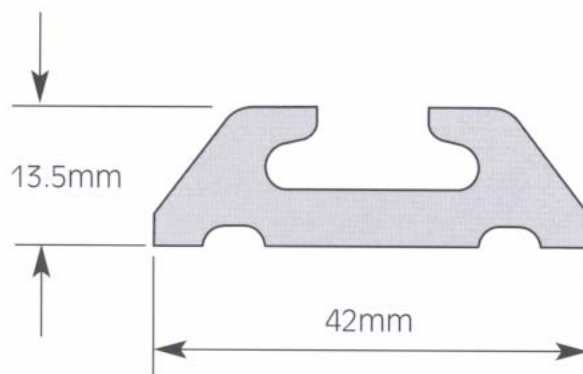

Surface Rail can be supplied un-drilled for the base fixing holes or drilled and countersunk, and is produced in 3.66 metre lengths.

- The floor rail is fixed to the vehicle structure using fasteners suitable for specific application.
- Specific end caps are available for surface rail.
- Recess in rail should be kept clear of debris to allow equipment to fit and move freely along the rails.

## **D. MAINTENANCE**

- Rail inserts or strips can be fitted to unused rail sections to aid housekeeping.
- Check rail for damage and corrosion.
- The rail should never come into contact with strong acid/ alkaline solutions as this will degrade the appearance and strength of the rail.
- If you intend using a proprietary cleaner on or near the rails, advice should be sought from its manufacturer to ensure it does not degrade the appearance and strength of the rail sections.



Unwin House • The Horseshoe • Coat Road  
Martock • Somerset • TA12 6EY • ENGLAND  
Tel: +44 (0)1935 827740 • Fax: +44 (0)1935 827760  
Email: [sales@unwin-safety.co.uk](mailto:sales@unwin-safety.co.uk)  
[www.unwin-safety.com](http://www.unwin-safety.com)