



ALUMINIUM REMOVABLE SEAT FIXTURES

Codes: SL/STD, SL/RS, SL/BCD & SL/STD2

USER OPERATING INSTRUCTIONS



Read instructions fully before use.

It is recommended that training be given on the proper use of this product.

**Retain this manual for future reference.
Include it with the product in the event of transfer to new users.
Additional copies are available upon request.**

Unwin House • The Horseshoe • Coat Road • Martock •
Somerset • TA12 6EY • UK

Tel: +44 (0)1935 827740 • Fax: +44 (0)1935 827760

Email: sales@unwin-safety.co.uk

www.unwin-safety.com



© 2008 C.N. Unwin Ltd. All rights reserved

UI1264B



CONTENTS

- A. Parts list
- B. Limitations of use
- C. Fitting removable seat fixtures onto seat frame
- D. Operating the removable seat fixture
- E. Spare parts/ancillary items
- F. Warranty

A. PARTS LIST

Each removable seat fixture is supplied with the following

- A - removable seat fixture
- B - 20mm (or 25mm—SL/RS) long M10 cap head screws
- C - M10 washers
- D - Foot
- E - Fixing holes M10

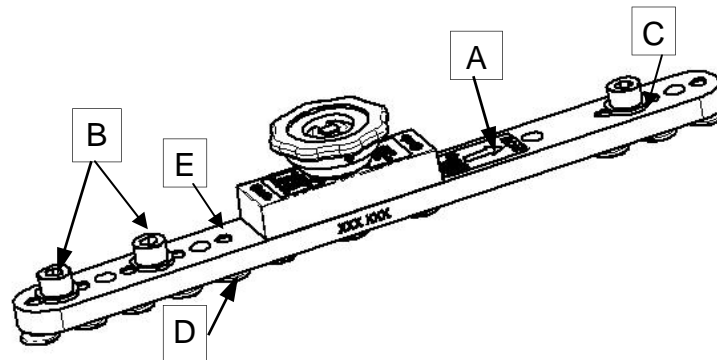

B. LIMITATIONS OF USE

1. This range of removable seat fixtures has been designed for use with a variety of seats where the intention is that they are easily moved or removed from the vehicle.
2. If seat belts are attached to the seat and the vehicle is to be sold within the EU, the vehicle builder will invariably require evidence that the assembly meets appropriate Directives.

Although the removable fixture has performed satisfactorily in tests where M1 loads were applied to a single seat up to 33 kg with three fixing bolts, care needs to be taken in reading across testing results from one installation to another. If doubt regarding a particular installation exists, refer to Unwin Safety Systems, the seat manufacturer or the vehicle builder.

3. Removable seat fixtures should **only** be fitted and used in the way described in this manual. If you have any queries on the installation or use of these products, please contact Unwin Safety Systems.
4. Should you need to use the seat fixture near a wheel arch, you must use the following seat fixture: SFX-05636-A. Please contact the sales office for details.

C. FITTING REMOVABLE SEAT FIXTURES ONTO SEAT

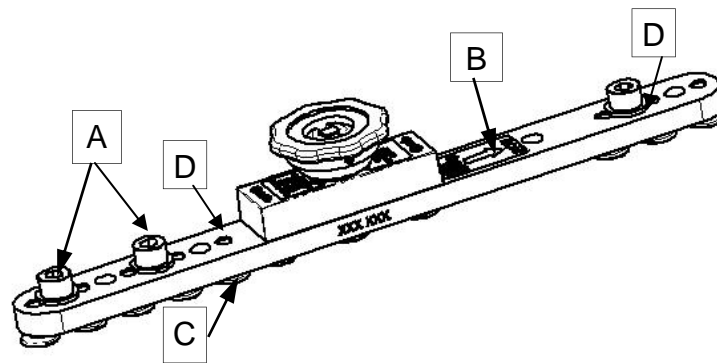

1. Two removable seat fixtures are normally required for each seat.
2. Remove the screws (A) from each removable seat fixture.
3. Place the seat on the removable seat fixtures ensuring that both have the arrow marked "FRONT" (B) pointing towards the front of the seat. This ensures the five rail fitting feet (C) are at the rear of the seat, however, if it is intended that the seat should face the rear, please contact Unwin Safety Systems.
4. The seat should be mounted as far forward as possible on each removable seat fixture. Line up at least two fixing holes (D) on the seat frame with two in each seat fixture, one from the cluster at the front and one from the rear.
DO NOT use the rearmost fixing hole of a removable seat fixture in isolation. It should only be used in conjunction with another fixing hole, where a pair of screws are being used to secure each rear leg of the frame.
5. To achieve maximum strength as an assembly the fixing screws must protrude beyond the base of the aluminium bar, thus ensuring maximum performance from the thread. The protrusion needs to be between 1.5 and 3 threads of the screw and must avoid being such that it makes contact with the top of the feet (C).
6. Screws supplied as standard with each removable seat fixture are 20mm long and, used with the washer supplied, suit the majority of applications. There are, however, 25 mm long screws available from Unwin Safety Systems should the frame thickness require a longer pattern, or fitted to the seat fixtures with product code SL/RS. If procured elsewhere the screws need to be grade 12.9 for optimum performance.
7. In fixing the screws a screw tightening torque of 25-30 Nm (18-22lbf) is recommended.
8. Unlock the anti-rattle mechanism of the removable seat fixture and withdraw location plunger. Offer seat assembly into a section of floor rail to ensure it slides freely.

D. OPERATING THE REMOVABLE SEAT FIXTURE



1

FITTING SEAT INTO THE RAILS

1. Turn the black handles anti-clockwise until a positive stop is reached. Lift the black handles and turn through 90° to raise the plunger (Fig. 1).
2. Fit seat fixtures into the rail and turn the black handles so they drop into slots.
3. Push the seat backward and forward slightly until the plungers drop to the bottom of the slots, ensuring total engagement of both plungers in the rails.
4. Turn the black handle clockwise to apply the “anti-rattle” mechanism (Fig. 2). **IMPORTANT: Tighten by hand only. Do not use tools of any kind.**



2

REMOVING SEAT FROM THE RAILS

1. Turn the black handle anti-clockwise until a positive stop is reached. This is the unlocked position. Lift the black handle and turn through 90° to raise the plunger (Fig. 1).
2. Lift seat out of the rail with a slight backward or forward movement, to allow the seat fixture feet to clear the rail cut-outs.

MAINTENANCE

Regularly check the equipment for damage or malfunction. If problems are identified make sure the item is replaced.

E. SPARE PARTS/ANCILLARY ITEMS

Additional screws and washers are available

- **SL/FIX** 20mm long M10 cap head screw and washer
- **SB-M10X25-B** 25mm long M10 cap head screw
- **WA-M10-Z** M10 washer

Please contact our sales office for details.

F. WARRANTY

Unwin products are extensively tested using Unwin rail, and our full warranty normally only applies to Unwin equipment when used in Unwin branded rail. Unwins have also participated in test programs with manufacturers of structural rail products and will support warranty on the Unwin products when used in conjunction with such jointly tested systems.

For further details on specific applications please contact the Sales Office.

In other situations using rail products for which Unwin has not participated in joint test programs, a limited Unwin warranty will apply.