

EasiSit

USER MANUAL



Please read instructions fully before use.

It is recommended that training on the proper use of this product be given before use.

**Retain this manual for future reference.
Include it with the product in the event of transfer to new users.
Additional copies are available upon request.**

Unwin House, The Horseshoe, Coat Road,
Martock, Somerset, TA12 6EY , UK

Tel: +44 (0)1935 827740 • Fax: +44 (0)1935 8277601

Email: sales@unwin-safety.co.uk

www.unwin-safety.com

© 2010 C.N. UNWIN LTD. ALL RIGHTS RESERVED



CONTENTS

- A. Limitations of use
- B. Positioning Rail Mounted EasiSit
- C. Positioning a Bolted EasiSit
- D. Before fitting the restraint
- E. Securing the wheelchair
- F. Securing the passenger
- G. Conversion to a seat
- H. Maintenance
- I. Inspection Checklist
- J. Check sheet
- K. Wearers belt instructions—General

A. Limitations of use

1. EasiSit is designed to secure both manual and powered wheelchairs weighing up to 85 kg and incorporates a passenger restraint.
2. Some wheelchairs need specific restraints, this is often true of buggy-type wheelchairs. If in doubt please contact Unwins or the wheelchair manufacturer.
3. Unwin products are extensively tested using Unwin rail & Solo system, and our full warranty normally only applies to Unwin equipment when used in Unwin branded rail or Unwin Solo. Unwins have also participated in test programs with manufacturers of structural rail products and will support warranty on the Unwin products when used in conjunction with such jointly tested systems. For further details on specific applications please contact the Sales Office.
In other situations using rail products for which Unwin has not participated in joint test programs, a limited Unwin warranty will apply.

B. Positioning Rail Mounted EasiSit

1. Place the EasiSit facing forwards on the rails in the desired position with the handled plunger extended up and the anti-rattle cam in its lowered position (rotated fully anti-clockwise) [1]. Use the wheels & curved ends of the rail fitting to aid positioning and insertion into the rail.
2. Once located in the rail, rotate both plungers to coincide with the vertical slots in the anti-rattle cam, and slide EasiSit along the rail until both plungers drop and lock in. Rotate both plunger housing assemblies clockwise until resistance is felt [2]. EasiSit is now securely located and rattle free, ready for use.
3. Release EasiSit from the rail by reversing the above sequence. Remember to use the curved rail fitting ends to locate the exact exit area of fitting to rail. Once aligned, carefully tilt EasiSit back onto its wheels and wheel away.

[1] Unlocked

Anti-rattle plunger housing fully anti clockwise & plunger raised & disengaged.

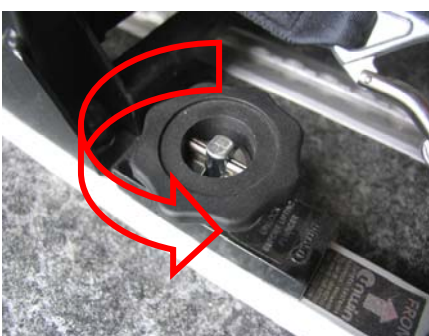

[2] To Lock

Drop plunger into position, engaging in rail, turn anti rattle assembly until resistance is felt.

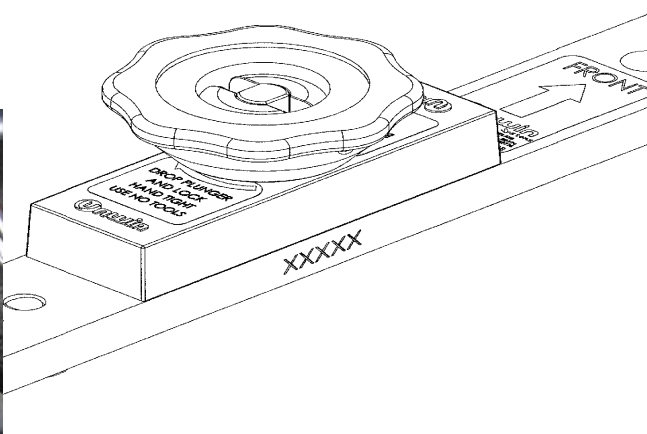

C. Positioning a Bolted EasiSit

For a permanent installation, EasiSit may be bolted directly into a vehicle, including into Unwin rail.

1. Carefully choose a suitable wheelchair space within the vehicle for EasiSit. Note the six fixing positions through the leg feet. Ensure that there are no obstructions directly beneath the fixing positions such as petrol tanks, brake lines or anything that may be damaged when drilling and bolting through the floor. If necessary, relocate the EasiSit to avoid potential problems.
2. When satisfied that the EasiSit is correctly positioned, mark the fixing positions and drill through the floor using an 11 mm drill bit. A simple card template can be made up if required as an aid to marking and drilling the fixing positions.
3. Underfloor support is required at all bolted positions. It is recommended that a plate 75mmx75mmx4mm (or equivalent) is used for each bolt location.
4. Install EasiSit and securely tighten all fixings.
5. Apply a proprietary under body sealant/paint to protect any drilled areas beneath the floor to preserve the vehicle's corrosion resistance.

Please note: Fixings are not supplied as different installations will require different lengths of bolt, under floor spreader plates and/or strengthening for optimum fitment. Regardless of length, we recommend that no fewer than six bolts are used at a minimum grade of 10.9 along with nylock or similar shake-proof nuts.

D. Before fitting restraint

1. Position the wheelchair centrally over the floor rails, (if rail mounted). Apply the brakes to ensure that the wheelchair cannot roll away.
2. **Note:** Electric wheelchairs may require an additional strap to secure the batteries, in case of query refer to the wheelchair manufacturer.
3. We advise that all ancillary equipment, such as oxygen cylinders, trays, bags etc are removed from the wheelchair and secured separately before transport.

E. Securing the wheelchair.

1. If EasiSit is set as a seat, lift the armrest(s), if fitted, into an upright position and fold the seat cushion (A).
2. Position the wheelchair at a convenient distance in front and away from the EasiSit, pull out each karabiner and attach to mainframe of the wheelchair. (Some manufacturers may indicate attachment points on the wheelchair frame for the karabiners.)
3. Move the wheelchair up to the EasiSit. Stand behind EasiSit and guide the wheelchair up to and against the telescopic stand-off bar (B), adjusting it for width/height if required. Height adjustment is achieved by releasing the two thumb screws and repositioning them along with the stand-off bar to the next row of holes. (Standard height indicated by yellow arrows). The standard position will generally be found to be the most suitable for the majority of wheelchairs.
4. Once the wheelchair is hard up against the stand-off bar, depress the foot pedal (C) fully until you hear a loud click as it locks in. Apply the wheelchair brakes.
5. Test that the wheelchair is secure by leaning on and then lifting its handles. Neither the front castors nor the rear wheels should be able to lift off the ground. If the wheelchair is felt not to be secure enough, it may be necessary to release the foot pedal and repeat step 5.
6. To release the wheelchair, simultaneously lift the red handle (D) (back of the seat) and raise the yellow foot pedal with your toe (C). Release the wheelchair brakes and move the wheelchair away from the EasiSit. Reapply the brakes and remove the karabiner straps, allowing them to retract to their storage position, clipped over the front leg cross rail. (E). Depress the foot pedal to remove any possible tripping hazard.

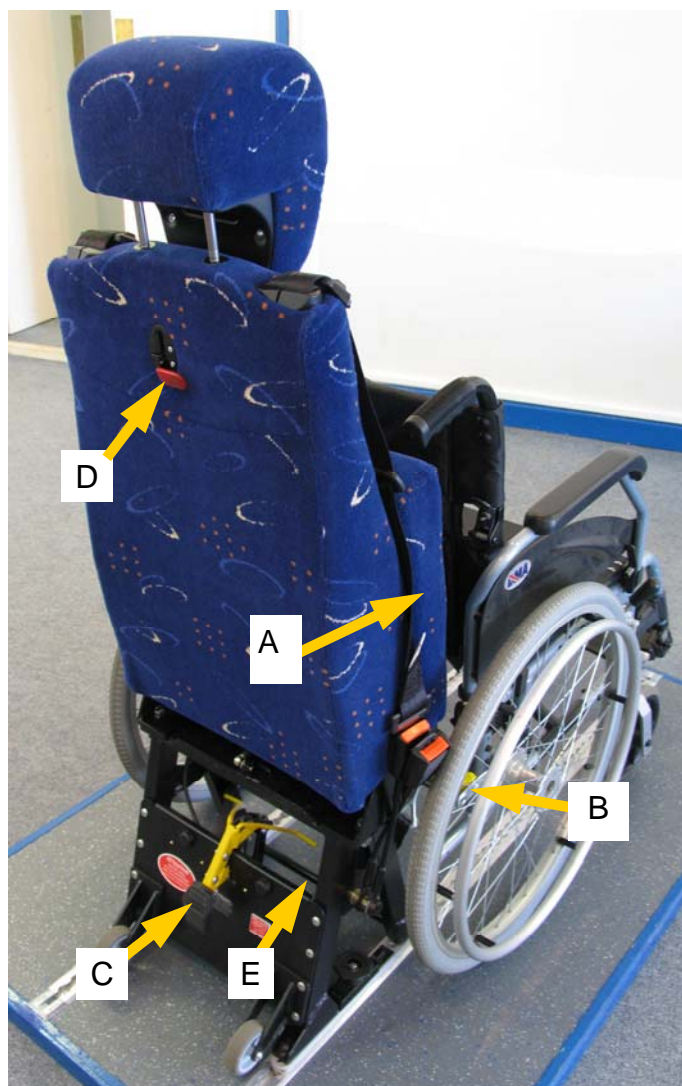

F. Securing the passenger

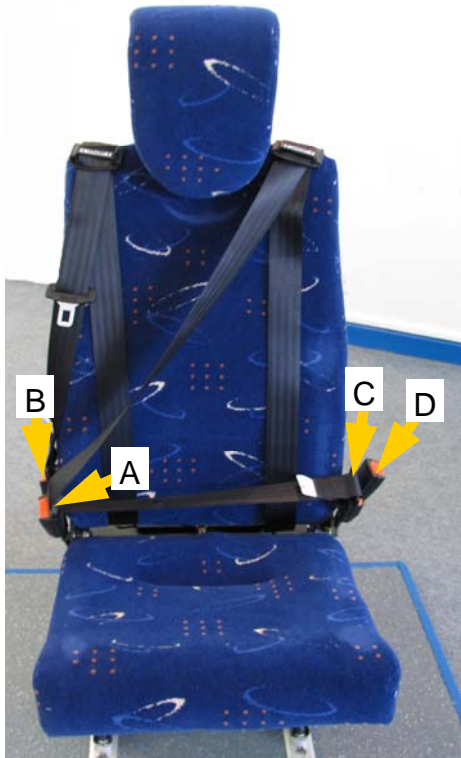

The EasiSit may have been fitted with a variety of different passenger restraint options. It will be necessary to identify which options are fitted to the EasiSit being used such that the attendant can best address the needs of both the wheelchair user and the able bodied.

The options are as follows:

- Left hand seat belt with height adjuster.
- Right hand seat belt with height adjuster.
- Both left & right hand seat belts with height adjusters forming a 'Cross' Strap.

Tip: The occupant restraint may be split to allow the lap belt element to pass through the arms of fixed arm wheelchairs, allowing for a more comfortable and better fitting belt.

The belt tongues are not interchangeable, and therefore cannot be fitted into the wrong stalks.

1. Pull enough webbing and fittings from the shoulder exit, (either left or right) to fit tongue (A) into stalk (B), to form the diagonal belt.
2. Pull the remaining tongue (C) across the occupant, (through a fixed arm rest if necessary), and clip into stalk (D). Adjust the height adjuster buckle for a comfortable fit across the occupant shoulder. This completes the lap and diagonal restraint.
3. If fitting a 'cross strap' repeat the procedure with the remaining strap.

G. Conversion to a seat

1. Check and confirm that the Karabiner straps are in their retracted storage position, clipped to the front leg cross rail, and that the foot pedal is depressed and locked down. This is important to remove any possible tripping hazard to other passengers and to keep the webbing clean and tidy.
2. Push in the ends of the telescopic stand off bar. Stand in front of EasiSit, hold the sides of the seat cushion and push it down to allow the frame to 'hinge' down to its horizontal position.

H. Maintenance

1. Regularly inspect the EasiSit for damage, wear or malfunction. If any problems are identified replace it immediately. Please refer to inspection checklist overleaf.
2. If the vehicle is involved in an accident when any restraints are deployed, remove them from service and replace immediately.

If in doubt about the condition or any aspect of an EasiSit, please contact Unwin Safety Systems for advice.

I. Inspection Checklist

Depending on frequency of use it is recommended that the EasiSit be inspected at least once a month.

SEAT

- Do the lockable seat fixtures operate as described in section B of this manual.
- Appearance/Condition of painted surfaces.
- Appearance/Condition of trim.
- Is there any loose strands/Pieces of material/trim.
- Can the seat cushion be lifted, with the aid of the gas spring, to its upright position.
- Does the gas spring hold the seat cushion in the upright position.
- Do the cushion sides hinge both inwards and outwards.
- Does there appear to be any damage to the cushion sides hinge mechanism.
- Does the seat cushion fold flat for use as an able bodied seat.

SEAT BELT

- Are all stalks attached tightly to the frame.
- Are all stalks intact and without damage.
- Do seat belt tongues lock into their corresponding stalks.
- Do the tongues release when the stalk release buttons are pressed.
- Is the height adjuster present on the shoulder belt.
- Does the height adjuster slide freely along the shoulder belt.
- Does the shoulder belt extend and retract from the exit guide.
- Is any webbing slack formed during occupant fitment taken up by the reel.
- Does retractor lock when EasiSit is inclined at an angle.
- Does retractor lock instantly when the webbing is snatch pulled.
- Does retractor take in when snatch pull is released.
- Does the webbing show any signs of wear/abrasion/damage.
- Do all webbing stitched areas look to be in good condition.

• WHEELCHAIR RESTRAINT

- Does foot pedal raise and lower smoothly.
- Does release lever lift and allow foot pedal to be raised.
- With foot pedal raised can karabiner straps be manually extended.
- Upon release of the karabiner straps do they retract back into the reel casings.
- Does karabiner gate open fully and close automatically upon release of the gate.
- Is the stitch pattern to the karabiner in good condition.
- Does the webbing show any signs of wear/abrasion/damage.
- Is the stand-off bar and retaining Knobs (x2) present.
- Can the stand-off bar be telescoped.
- Are the plastic grip covers present and in good condition.
- Can the stand-off bar assembly be moved to another height position.

K. WEARERS INSTRUCTIONS

USING THE SEAT BELT— Seat belts should be worn on all journeys

When in use the lap belt part of the seat belt should be positioned on the bony part of the hip and the buckle should lie on or below the hip. When inserting a tongue into a buckle ensure that a positive audible 'click' is heard.

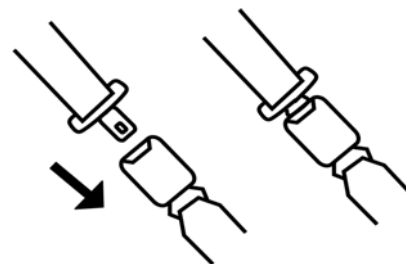

TESTING THE HARNESS

The design of the reel makes it lock the webbing by both a sudden withdrawal of the webbing and deceleration, or cornering of the vehicle. To test the former mode of locking, rapidly pull the webbing from the reel. The reel should lock within a few inches. To test the second mode of locking the vehicle may be parked on a sharp incline (approximately 30°), the reel should lock and hold the webbing in place. The lock will disengage itself automatically when the vehicle is level.

CLEANING THE HARNESS

No chemical cleaners should be used on the webbing. If it becomes soiled, sponge with warm water, using a non-detergent soap and allow to dry naturally, not by artificial heat or direct exposure to the sun. Never attempt to bleach or re-dye. the webbing.

WARNING

Always ensure that the belt is not twisted on the body, or through the anchorage points. Always wear the belt as a complete lap and diagonal assembly. Do not use the belt for more than one person, even small children. Do not allow the belt to chafe against sharp edges. Periodically inspect the webbing for abrasion, paying particular attention to anchorage points and adjusting devices. Any safety belt which has been subjected to a shock load should in the interest of safety, be renewed.



Unwin House • The Horseshoe • Coat Road
Martock • Somerset • TA12 6EY • UK

Tel: +44 (0)1935 827740 • Fax: +44 (0)1935 827760
Email: sales@unwin-safety.co.uk
Web: www.unwin-safety.com