

Unwin Safety Systems Innotrax M2 FLAT FLOOR



Unwin Safety Systems introduce the new Innotrax Flat Floor rail system. Innotrax Flat Floor offers a complete flooring solution for accessible vehicles, providing safe securement of wheelchairs and maximum seating space with the removal of protruding internal wheelarches.

In standard accessible vehicle conversions, rear wheelarches limit internal floor space and reduce the number of wheelchair and non-wheelchair occupants that can be transported. With the Innotrax Flat Floor system, this problem is eliminated, resulting in additional seating space for both able-bodied and disabled passengers.

Specifically designed for the Mercedes Sprinter 5 series and Volkswagen Crafter CR50, the Innotrax Flat Floor is bonded on a 100mm raised platform to allow suspension clearance and provides a smooth, comfortable ride for every passenger.

As with all Unwin products, the Innotrax Flat Floor has been stringently tested to ensure maximum safety. The system conforms to M2 vehicle test standards and has been witnessed by both the designated UK Vehicle Type Approval Authority – the Vehicle Certification Agency and TÜV Product Services – a leading European expert on testing and certification.

This new floor and rail system provides one of the quickest and easiest solutions to fit on the market. Based on a standard accessible vehicle, the Innotrax Flat Floor can be installed within approximately four hours which greatly increases output for vehicle converters.

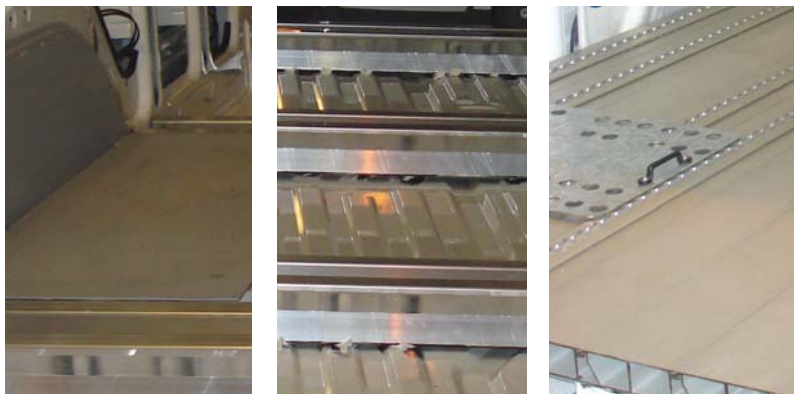

Tel: +44 (0)1935 827740

Email: sales@unwin-safety.co.uk

Internet: www.unwin-safety.com

...Trust Unwin

VB

airsuspension

Unwin
Safety Systems

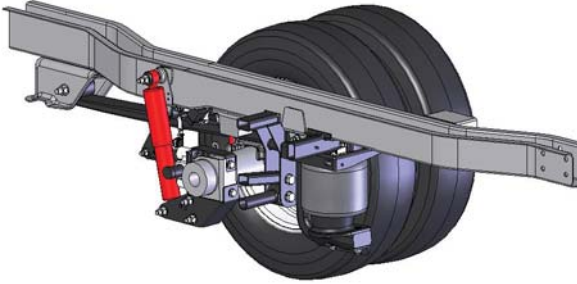

SUSPENSION KIT

When an Innotrax Flat Floor is installed, the vehicle suspension will require modification by means of a suspension kit. The suspension kit allows for the reduced clearance from the underside of the wheelarch to the top of the tyre. The same applies when fitting an under floor tail-lift, as the cassette will not physically fit between the leaf-springs.

Unwin Safety Systems and VB-Airsuspension (*the preferred suspension supplier to both Mercedes and Volkswagen*) have collaborated to offer a range of suspension kit option for the Innotrax Flat Floor, under floor tail-lift or both. Each suspension system provides different benefits but each solution ensures that both the suspension and therefore the vehicle are safe.

Spacer kit

The standard spacer kit (*INNO/SPACKERKIT*) is a non-adjustable solution which is mounted to the existing leaf spring suspension. This ensures that the vehicle has a higher ride-height. This solution does not offer any improvement to the ride comfort or stability of the vehicle, but by increasing the suspension it compensates for the reduced wheelarch clearance and creates enough space for a cassette-lift to be installed.

Please contact Unwin Sales Office for information on this product.

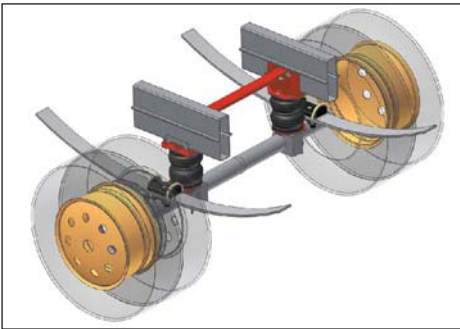

Semi air-suspension kit

The Semi air-suspension (VB-SemiAir) enables the driver to adjust the suspension (to a certain degree), depending on the load of the vehicle. An air-spring is fitted between the chassis and the rear axle to supplement the existing leaf spring, acting as a progressive bump-stop. By varying the pressure in the bellows, the driver is able to adjust the ride height. Left and right can also be adjusted independently, making it possible to compensate a slightly uneven weight distribution. This solution offers increased stability and a slightly improved ride comfort.

Please contact VB-Airsuspension for information on this product.

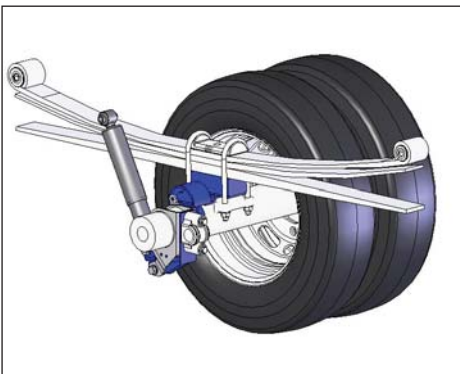

Unwin Safety Systems

Unwin House, The Horseshoe,
Coat Road, Martock,
Somerset TA12 6EY

Tel: + 44 1935 827740

Email: sales@unwin-safety.co.uk

Internet: www.unwin-safety.com

Unwin
Safety Systems

VB
airsuspension

VB-Airsuspension UK Ltd

Unit 13, Elder Court, Lions Drive,
Shadsworth Business Park,
Blackburn, Lancashire BB1 2EQ

Tel: + 44 1254 848010

Email: drinkwater@vbairsuspension.co.uk

Internet: www.vbairsuspension.com

Full air-suspension kit

A full air-suspension system (VB-FullAir) is a fully automatic, adjustable solution for suspension problems. The existing leaf or coil spring is replaced by a complete air-suspension system (including air-springs, shock absorbers, compressor, 2 height-sensors and an electronic control unit). The air-suspension system filters road-surface imperfections, thus improving the ride comfort. The vehicle will remain at all times at its pre-set ride height and will stay level, no matter how the vehicle is loaded. Both the road-holding and the stability of the vehicle will be improved, thereby enhancing safety as well as comfort.

Please contact VB-Airsuspension for information on this product.